

电子类电磁阀线圈

Electric Solenoid Coil



产品型号 / Coil type.:1030

产品编号 / Code no.:BRS-C027

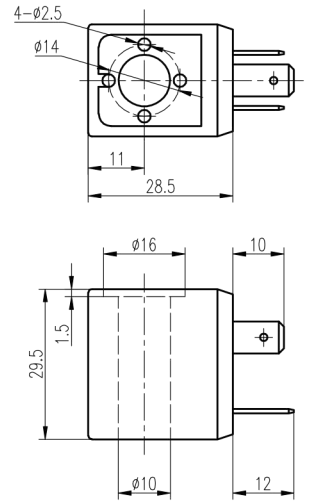

技术参数 / Technical Data

标称电压 Standard Voltage	DC:12V/24V; AC:24V/110V/220V
电压范围 Voltage range	DC \pm 10%,AC-10%~+15%
额定功率 Rated Power	AC: 5.5VA; DC:4.8W; others on request 其它可定制
工作时间 Duty Cycle	ED100% (continuous)

保护等级 Protection degree	IP65(EN60529)
绝缘等级 Coil Insulation	Class F, H
环境温度 Ambient temperature	-20°C~+50°C
工作频率 Frequency	50/ 60 HZ

主要结构 / General Construction

骨架材料 Bobbin material	PBT/PA66/PPS/PET
铜线等级 Coil wire	Class F wire,-155°C ; Class H wire,- 200°C(IEC317-8)
支架 Magnetic yoke	Made by low carbon iron 高导磁低碳钢
封塑材料 Encapsulation material	PA66 30% fiberglass 热塑性塑封料 thermoplastic material

接电方式 / Electrical Connections

插脚式 DIN43650B Spade plug

应用 / Application

广泛应用于家电, 气动, 蒸汽等行业。

Suit for solenoid valve which widely used in small Household Appliances,Pneumatics,Steam industries.