

气动类电磁阀线圈



Pneumatic Solenoid Coil



产品型号 / Coil type.:4V210

产品编号 /Code no.:BRS-C001

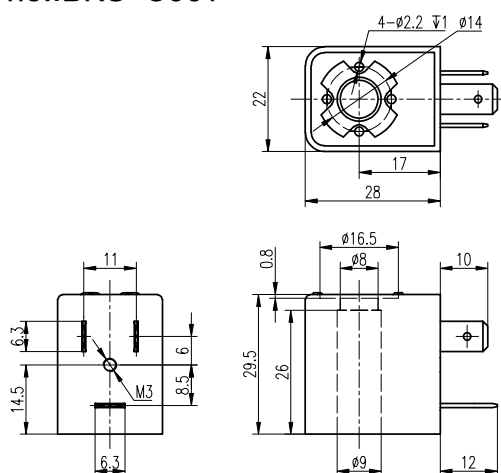

技术参数 /Technical Data

标称电压 Standard Voltage	DC:12V/24V; AC:24V/110V/220V
电压范围 Voltage range	DC±10%; AC -15%~+10%
额定功率 Rated Power	AC: 3.5VA/5.5VA/6VA; DC:3W/4.8W/6W
工作时间 Duty Cycle	ED100% (continuous)

保护等级 Protection degree	IP65(EN60529)
绝缘等级 Coil Insulation	F/ H
环境温度 Ambient temperature	-20°C~+50°C
工作频率 Frequency	50/ 60 HZ

主要结构 /General Construction

骨架材料 Bobbin material	PBT/PA66/PPS/PET
铜线等级 Coil wire	F155°C/ H180°C/N200/R220 (IEC317-8)
支架 Magnetic yoke	Made by low carbon iron 高导磁低碳钢
封塑材料 Encapsulation material	PA66 30% fiberglass

接电方式 /Electrical Connections

插脚式 DIN43650B Spade plug

应用 /Application

适用于 5/2 通气控电磁阀，如亚德客型。

Suitable for directional control valve, 5/2 way pneumatic solenoid valve, like Airtac 4V series.

气动类电磁阀线圈



Pneumatic Solenoid Coil



产品型号 / Coil type.:4V210RG

产品编号 / Code no.:BRS-C002

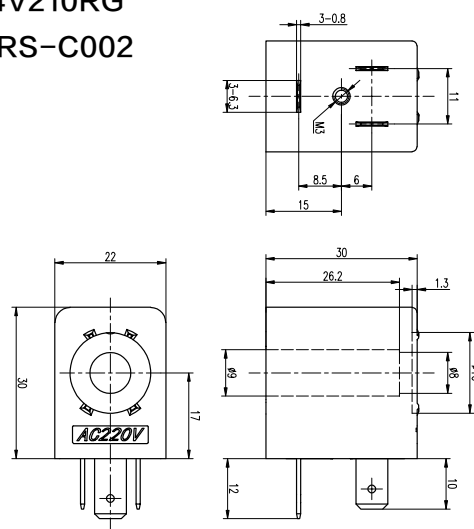

技术参数 / Technical Data

标称电压 Standard Voltage	DC:12V/24V; AC:24V/110V/220V
电压范围 Voltage range	DC \pm 10%; AC -15%~10%
额定功率 Rated Power	AC: 3.5VA/5.5VA/6VA; DC:3W/4.8W/6W
工作时间 Duty Cycle	ED100% (continuous)

保护等级 Protection degree	IP65(EN60529)
绝缘等级 Coil Insulation	Class F, H
环境温度 Ambient temperature	-20°C~+50°C
工作频率 Frequency	50/ 60 HZ

主要结构 / General Construction

骨架材料 Bobbin material	PBT/PA66/PPS/PET
铜线等级 Coil wire	F155°C/ H180°C/N200/R220 (IEC317-8)
支架 Magnetic yoke	Made by low carbon iron 高导磁低碳钢
封塑材料 Encapsulation material	BMC thermosetting material 热固性塑封料

接电方式 / Electrical Connections

插脚式 DIN43650B spade plug

应用 / Application

适用于 5/2 通气控电磁阀, 如亚德客型。

Suitable for 5/2 way pneumatic solenoid valve, like Airtac 4V series.

气动类电磁阀线圈



Pneumatic Solenoid Coil



产品型号 / Coil type.:3130C

产品编号 / Code no.:BRS-C004

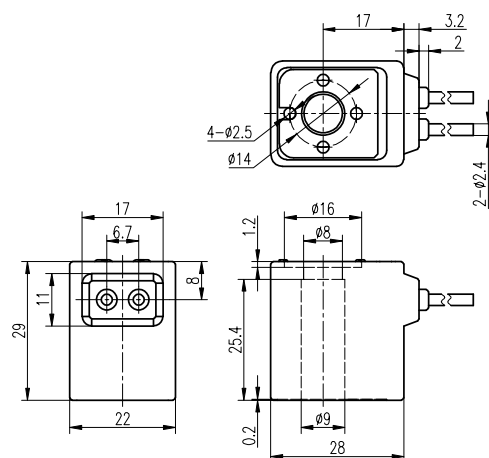

技术参数 / Technical Data

标称电压 Standard Voltage	DC:12V/24V; AC:24V/36V/110V/220V
电压范围 Voltage range	DC \pm 10%; AC -15%~+10%
额定功率 Rated Power	AC: 3.5VA/5.5VA/6VA; DC:3W/4.8W/6W 其它可定制
工作时间 Duty Cycle	ED100% (continuous)

保护等级 Protection degree	IP65(EN60529)
绝缘等级 Coil Insulation	Class F, H
环境温度 Ambient temperature	-20°C~+50°C
工作频率 Frequency	50/ 60 HZ

主要结构 / General Construction

骨架材料 Bobbin material	PBT/PA66/PPS/PET
铜线等级 Coil wire	Class F wire, -155°C ; Class H wire, - 200°C(IEC317-8)
支架 Magnetic yoke	Made by low carbon iron 高导磁低碳钢
封塑材料 Encapsulation material	PA66 30% fiberglass thermoplastic material 热塑性塑封料

接电方式 / Electrical Connections

引线式 Flying leads

应用 / Application

适用于 5/2 通气控电磁阀。

Suitable for directional control valve,
5/2 way pneumatic solenoid valve.

气动类电磁阀线圈



Pneumatic Solenoid Coil



产品型号 / Coil type.:A044

产品编号 / Code no.:BRS-C005

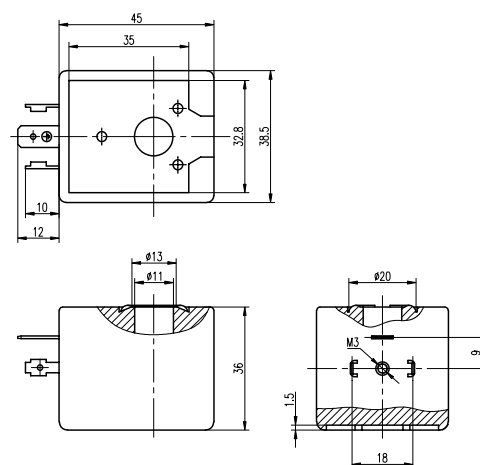

技术参数 / Technical Data

标称电压 Standard Voltage	DC:12V/24V; AC:24V/110V/220V
电压范围 Voltage range	DC \pm 10%; AC -15%~+10%
额定功率 Rated Power	AC: 15VA/22VA; DC:20W; others on request 其它可定制
工作时间 Duty Cycle	ED100% (continuous)

保护等级 Protection degree	IP65(EN60529)
绝缘等级 Coil Insulation	Class H
环境温度 Ambient temperature	-20°C~+50°C
工作频率 Frequency	50/ 60 HZ

主要结构 / General Construction

骨架材料 Bobbin material	PBT/PA66/PPS/PET
铜线等级 Coil wire	Class H-180°C (IEC317-8)
支架 Magnetic yoke	Made by low carbon iron 高导磁低碳钢
封塑材料 Encapsulation material	BMC thermosetting material 热固性塑封料

接电方式 / Electrical Connections

插脚式 DIN43650A spade plug

应用 / Application

适用于脉冲除尘阀, 水阀等。

Suitable for ASCO type Dust collector valves, Pulse jet valves, Water valves.

气动类电磁阀线圈



Pneumatic Solenoid Coil



产品型号 / Coil type.:A051

产品编号 / Code no.:BRS-C006

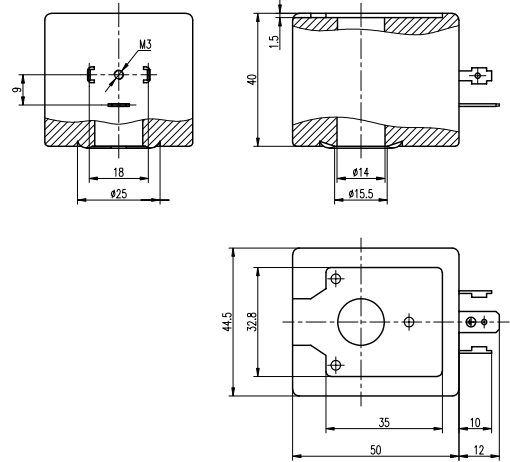

技术参数 / Technical Data

标称电压 Standard Voltage	DC:12V/24V; AC:24V/110V/220V
电压范围 Voltage range	DC \pm 10%; AC -15%~+10%
额定功率 Rated Power	AC: 22VA/28VA; DC:18W; others on request 其它可定制
工作时间 Duty Cycle	ED100% (continuous)

保护等级 Protection degree	IP65(EN60529)
绝缘等级 Coil Insulation	Class H
环境温度 Ambient temperature	-20°C~+50°C
工作频率 Frequency	50/ 60 HZ

主要结构 / General Construction

骨架材料 Bobbin material	PBT/PA66/PPS/PET
铜线等级 Coil wire	Class H wire-180°C (IEC317-8)
支架 Magnetic yoke	Made by low carbon iron 高导磁低碳钢
封塑材料 Encapsulation material	BMC thermosetting material 热固性塑封料

接电方式 / Electrical Connections

插脚式 DIN43650A Spade plug

应用 / Application

适用于脉冲除尘阀, 水阀等。

Suitable for ASCO type Dust collector valves, Pulse jet valves, Water valves.

气动类电磁阀线圈



Pneumatic Solenoid Coil



产品型号 / Coil type.:CY123

产品编号 / Code no.:BRS-C007

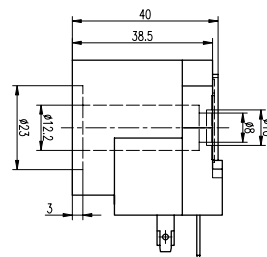
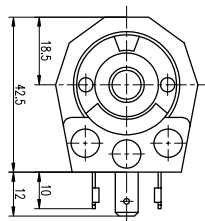
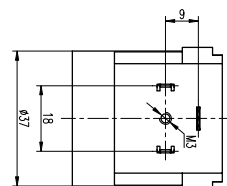

技术参数 / Technical Data

标称电压 Standard Voltage	DC:12V/24V; AC:24V/110V/220V
电压范围 Voltage range	DC \pm 10%; AC -15%~+10%
额定功率 Rated Power	AC: 25VA; DC:21W; others on request 其它可定制
工作时间 Duty Cycle	ED100% (continuous)

保护等级 Protection degree	IP65(EN60529)
绝缘等级 Coil Insulation	Class F, H
环境温度 Ambient temperature	-20°C~+50°C
工作频率 Frequency	50/ 60 HZ

主要结构 / General Construction

骨架材料 Bobbin material	PBT/PA66/PPS/PET
铜线等级 Coil wire	Class H wire - 200°C (IEC317-8)
支架 Magnetic yoke	Made by low carbon iron 高导磁低碳钢
封塑材料 Encapsulation material	PA66 30% fiberglass 热塑性塑封料

接电方式 / Electrical Connections

插脚式 DIN43650A Spade plug

应用 / Application

适用于脉冲除尘阀, 水阀等。

Suitable for ASCO type Dust collector valves, Pulse jet valves, Water valves.

气动类电磁阀线圈



Pneumatic Solenoid Coil

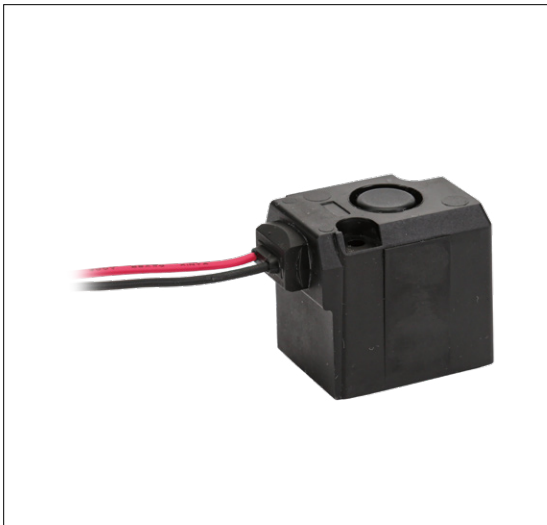

产品型号 / Coil type.:VT307

产品编号 / Code no.:BRS-C008

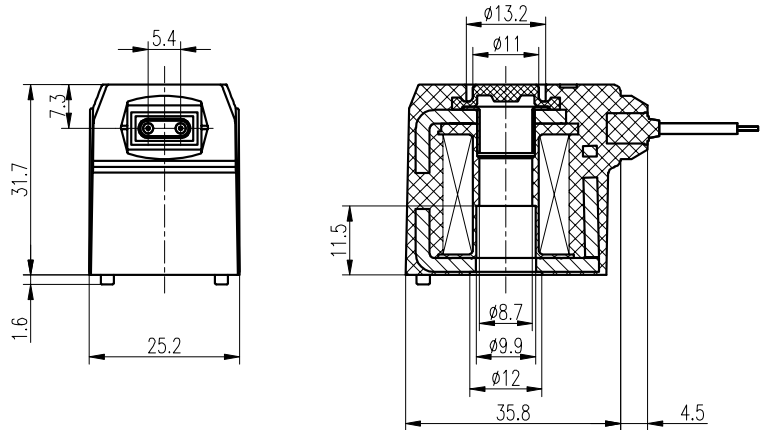

技术参数 / Technical Data

标称电压 Standard Voltage	DC:12V/24V; AC:24V/110V/220V
电压范围 Voltage range	DC \pm 10%; AC -15%~+10%
额定功率 Rated Power	DC:4W; others on request 其它可定制
工作时间 Duty Cycle	ED100% (continuous)

保护等级 Protection degree	IP65(EN60529)
绝缘等级 Coil Insulation	Class F, H
环境温度 Ambient temperature	-20°C~+50°C
工作频率 Frequency	50/ 60 HZ

主要结构 / General Construction

骨架材料 Bobbin material	PBT
铜线等级 Coil wire	Class F / H wire (IEC317-8)
支架 Magnetic yoke	Made by low carbon iron 高导磁低碳钢
封塑材料 Encapsulation material	BMC thermosetting material 热固性塑封料

接电方式 / Electrical Connections

引线式 Flying lead

应用 / Application

适用于 SMC 型 VT307 电磁阀。
Suitable for SMC type VT307 solenoid valve .

气动类电磁阀线圈



Pneumatic Solenoid Coil



产品型号 / Coil type.:0200

产品编号 / Code no.:BRS-C009

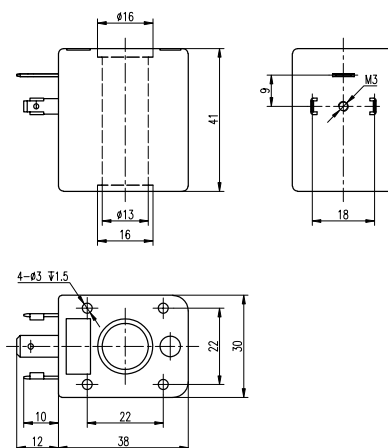

技术参数 / Technical Data

标称电压 Standard Voltage	DC:12V/24V; AC:24V/110V/220V
电压范围 Voltage range	DC \pm 10%; AC -15%~+10%
额定功率 Rated Power	AC: 15VA/18VA; DC:12W; others on request 其它可定制
工作时间 Duty Cycle	ED100% (continuous)

保护等级 Protection degree	IP65(EN60529)
绝缘等级 Coil Insulation	Class F, H
环境温度 Ambient temperature	-20°C~+50°C
工作频率 Frequency	50/ 60 HZ

主要结构 / General Construction

骨架材料 Bobbin material	PBT/PA66/PPS/PET
铜线等级 Coil wire	Class F wire,-155°C ; Class H wire,- 200°C(IEC317-8)
支架 Magnetic yoke	Made by low carbon iron 高导磁低碳钢
封塑材料 Encapsulation material	BMC thermosetting material 热固性塑封料

接电方式 / Electrical Connections

插脚式 DIN43650A spade plug

应用 / Application

适用于气动，流体，海隆系列电磁阀。

Suitable for pneumatic solenoid valve,fluid control solenoid valve,like HERION drain valves.

气动类电磁阀线圈



Pneumatic Solenoid Coil



产品型号 / Coil type.:0200D

产品编号 / Code no.:BRS-C010

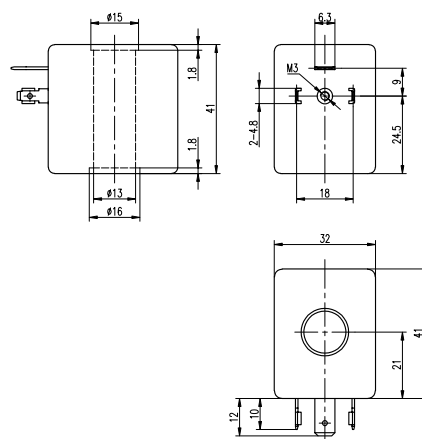

技术参数 / Technical Data

标称电压 Standard Voltage	DC:12V/24V; AC:24V/110V/220V
电压范围 Voltage range	DC \pm 10%; AC -15%~+10%
额定功率 Rated Power	AC:15VA/18VA; DC:12W; others on request 其它可定制
工作时间 Duty Cycle	ED100% (continuous)

保护等级 Protection degree	IP65(EN60529)
绝缘等级 Coil Insulation	Class F, H
环境温度 Ambient temperature	-20°C~+50°C
工作频率 Frequency	50/ 60 HZ

主要结构 / General Construction

骨架材料 Bobbin material	PBT/PA66/PPS/PET
铜线等级 Coil wire	Class F wire, -155°C ; Class H wire, - 200°C(IEC317-8)
支架 Magnetic yoke	Made by low carbon iron 高导磁低碳钢
封塑材料 Encapsulation material	BMC thermosetting material 热固性塑封料

接电方式 / Electrical Connections

插脚式 DIN43650A spade plug

应用 / Application

适用于气动, 流体, 海隆系列电磁阀。

Suitable for pneumatic solenoid valve, fluid control solenoid valve, like HERION drain valves.

流体类电磁阀线圈



Fluid control Solenoid Coil



产品型号 / Coil type.:AB310

产品编号 / Code no.:BRS-C011

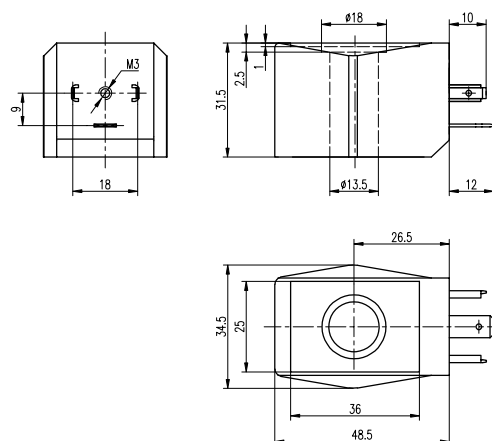

技术参数 / Technical Data

标称电压 Standard Voltage	DC:12V/24V; AC:24V/110V/220V
电压范围 Voltage range	DC \pm 10%; AC -15%~+10%
额定功率 Rated Power	AC: 15VA; DC:11W/13W; others on request 其它可定制
工作时间 Duty Cycle	ED100% (continuous)

保护等级 Protection degree	IP65(EN60529)
绝缘等级 Coil Insulation	Class H
环境温度 Ambient temperature	-20°C~+50°C
工作频率 Frequency	50/ 60 HZ

主要结构 / General Construction

骨架材料 Bobbin material	PBT/PA66/PPS/PET
铜线等级 Coil wire	Class H wire -180°C (IEC317-8)
支架 Magnetic yoke	Made by low carbon iron 高导磁低碳钢
封塑材料 Encapsulation material	BMC thermosetting material 热固性塑封料

接电方式 / Electrical Connections

插脚式 DIN43650A spade plug

应用 / Application

适用于 2 通流体控制阀, 蒸汽阀等。

Suitable for Pneumatic solenoid valves, steam solenoid valves, 2 way fluid control solenoid valves.

流体类电磁阀线圈



Fluid control Solenoid Coil



产品型号 / Coil type.: AB410

产品编号 / Code no.: BRS-C012

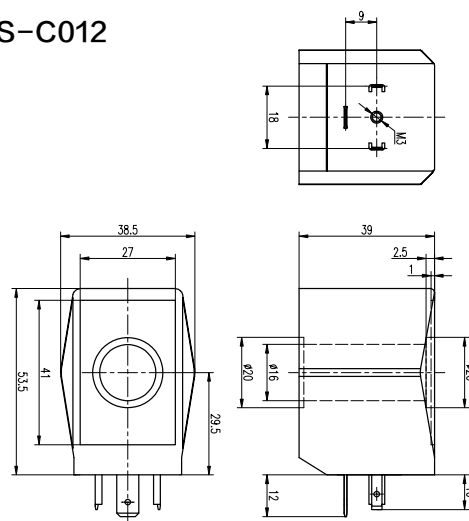

技术参数 / Technical Data

标称电压 Standard Voltage	DC:12V/24V; AC:24V/110V/220V
电压范围 Voltage range	DC \pm 10%; AC -15%~+10%
额定功率 Rated Power	AC: 26VA; DC:18W; others on request 其它可定制
工作时间 Duty Cycle	ED100% (continuous)

保护等级 Protection degree	IP65(EN60529)
绝缘等级 Coil Insulation	Class H
环境温度 Ambient temperature	-20°C~+50°C
工作频率 Frequency	50/ 60 HZ

主要结构 / General Construction

骨架材料 Bobbin material	PBT/PA66/PPS/PET
铜线等级 Coil wire	Class H wire - 200°C (IEC317-8)
支架 Magnetic yoke	Made by low carbon iron 高导磁低碳钢
封塑材料 Encapsulation material	BMC thermosetting material 热固性塑封料

接电方式 / Electrical Connections

热固性塑封料 DIN43650A Spade plug

应用 / Application

适用于 2 通流体控制阀, 蒸汽阀等。

Suitable for Pneumatic solenoid valves, steam solenoid valves, 2 way fluid control solenoid valves.

流体类电磁阀线圈



Fluid control Solenoid Coil



产品型号 / Coil type.:AB510

产品编号 / Code no.:BRS-C013

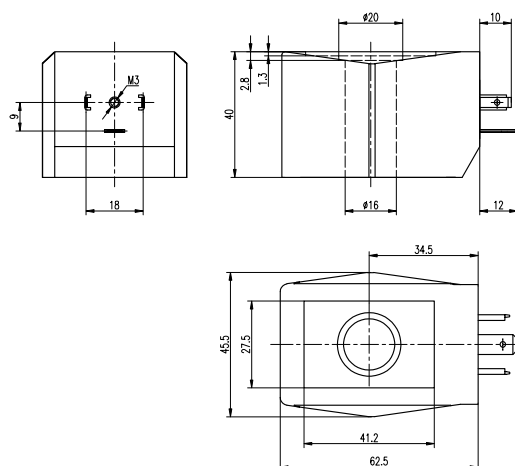

技术参数 / Technical Data

标称电压 Standard Voltage	DC:12V/24V; AC:24V/110V/220V
电压范围 Voltage range	DC \pm 10%; AC -15%~+10%
额定功率 Rated Power	AC: 28VA; DC:31W; others on request 其它可定制
工作时间 Duty Cycle	ED100% (continuous)

保护等级 Protection degree	IP65(EN60529)
绝缘等级 Coil Insulation	Class H
环境温度 Ambient temperature	-20°C~+50°C
工作频率 Frequency	50/ 60 HZ

主要结构 / General Construction

骨架材料 Bobbin material	PBT/PA66/PPS/PET
铜线等级 Coil wire	Class H wire - 180°C (IEC317-8)
支架 Magnetic yoke	Made by low carbon iron 高导磁低碳钢
封塑材料 Encapsulation material	BMC thermosetting material 热固性塑封料

接电方式 / Electrical Connections

插脚式 DIN43650A Spade plug

应用 / Application

适用于 2 通流体控制阀, 蒸汽阀等。

Suitable for Pneumatic solenoid valves, steam solenoid valves, 2 way fluid control solenoid valves.

流体类电磁阀线圈



Fluid control Solenoid Coil



产品型号 / Coil type.:006

产品编号 / Code no.:BRS-C014

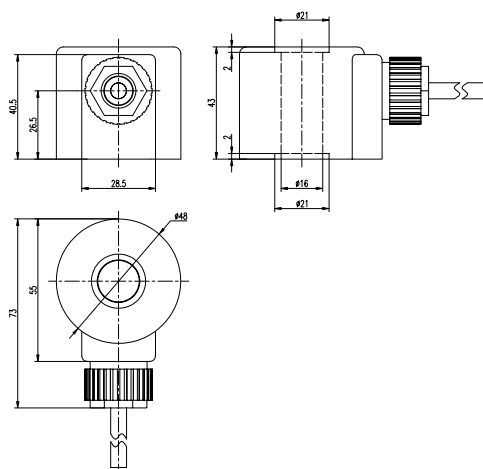

技术参数 / Technical Data

标称电压 Standard Voltage	DC:12V/24V; AC:24V/110V/220V
电压范围 Voltage range	DC \pm 10%,AC-15%~+10%
额定功率 Rated Power	AC: 22VA; DC:18W; others on request 其它可定制
工作时间 Duty Cycle	ED100% (continuous)

保护等级 Protection degree	IP67(EN60529)
绝缘等级 Coil Insulation	Class H
环境温度 Ambient temperature	-20°C~+50°C
工作频率 Frequency	50/ 60 HZ

主要结构 / General Construction

骨架材料 Bobbin material	PBT/PA66/PPS/PET
铜线等级 Coil wire	Class H wire -180°C (IEC317-8)
支架 Magnetic yoke	Made by low carbon iron 高导磁低碳钢
封塑材料 Encapsulation material	BMC thermosetting material 热固性塑封料

接电方式 / Electrical Connections

引线式 Cable leading type

应用 / Application

广泛应用于水下喷泉,2 通电电磁阀。

Widely used for fountain Solenoid valve, water proof, 2 Way Solenoid valve.

流体类电磁阀线圈



Fluid control Solenoid Coil



产品型号 / Coil type.:0543

产品编号 / Code no.:BRS-C015

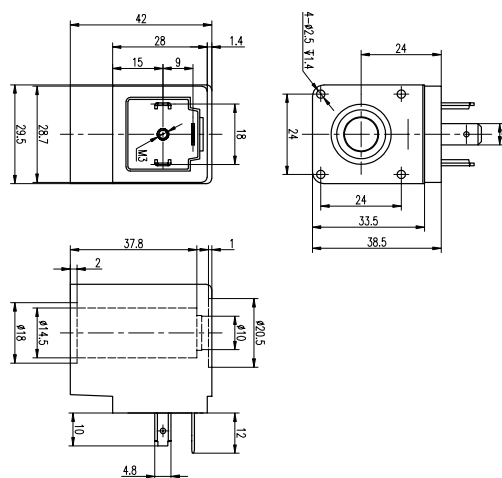

技术参数 / Technical Data

标称电压 Standard Voltage	DC:12V/24V; AC:24V/110V/220V
电压范围 Voltage range	DC \pm 10%,AC-10%~15%
额定功率 Rated Power	AC: 22VA; DC:12W; others on request 其它可定制
工作时间 Duty Cycle	ED100% (continuous)

保护等级 Protection degree	IP65(EN60529)
绝缘等级 Coil Insulation	Class H
环境温度 Ambient temperature	-20°C~+50°C
工作频率 Frequency	50/ 60 HZ

主要结构 / General Construction

骨架材料 Bobbin material	PBT/PA66/PPS/PET
铜线等级 Coil wire	Class H wire - 180°C (IEC317-8)
支架 Magnetic yoke	Made by low carbon iron 高导磁低碳钢
封塑材料 Encapsulation material	BMC thermosetting material 热固性塑封料

接电方式 / Electrical Connections

插脚式 DIN43650A Spade plug

应用 / Application

适用于 2 通流体控制阀, 蒸汽阀等。
Suitable for Pneumatic solenoid valves, steam solenoid valves, 2 way fluid control solenoid valves.

流体类电磁阀线圈



Fluid control Solenoid Coil



产品型号 / Coil type.:0545

产品编号 / Code no.:BRS-C016

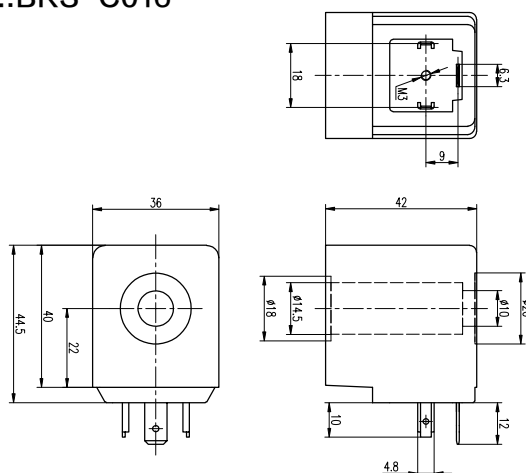

技术参数 / Technical Data

标称电压 Standard Voltage	DC:12V/24V; AC:24V/110V/220V
电压范围 Voltage range	DC \pm 10%,AC-10%~15%
额定功率 Rated Power	AC: 28VA; DC:18W; others on request 其它可定制
工作时间 Duty Cycle	ED100% (continuous)

保护等级 Protection degree	IP65(EN60529)
绝缘等级 Coil Insulation	Class H
环境温度 Ambient temperature	-20 $^{\circ}$ C~+50 $^{\circ}$ C
工作频率 Frequency	50/ 60 HZ

主要结构 / General Construction

骨架材料 Bobbin material	PBT/PA66/PPS/PET
铜线等级 Coil wire	Class H wire -180 $^{\circ}$ C (IEC317-8)
支架 Magnetic yoke	Made by low carbon iron 高导磁低碳钢
封塑材料 Encapsulation material	BMC thermosetting material 热塑性塑封料

接电方式 / Electrical Connections

插脚式 DIN43650A spade plug

应用 / Application

适用于 2 通流体控制阀, 蒸汽阀等。

Suitable for Pneumatic solenoid valves, steam solenoid valves, 2 way fluid control solenoid valves

液压类电磁阀线圈



Hydraulic Solenoid Coil



产品型号 / Coil type.:13372

产品编号 / Code no.:BRS-C017

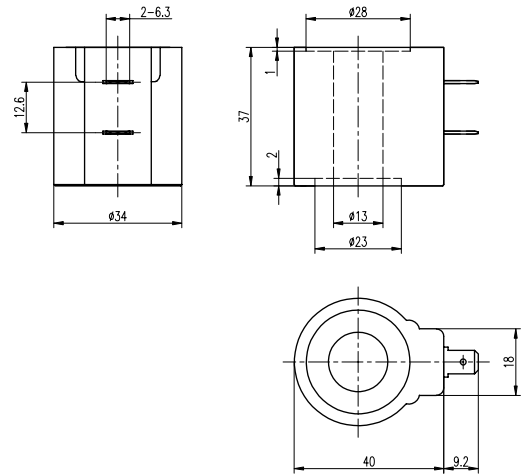

技术参数 / Technical Data

标称电压 Standard Voltage	DC:12V/24V; AC:24V/220V/380V
电压范围 Voltage range	DC \pm 10%; AC -15%~+10%
额定功率 Rated Power	AC: 8VA; DC:18W, others upon request 其它可定制
工作时间 Duty Cycle	ED100% (continuous)

保护等级 Protection degree	IP65(EN60529)
绝缘等级 Coil Insulation	Class H
环境温度 Ambient temperature	-20°C~+50°C
工作频率 Frequency	50/ 60 HZ

主要结构 / General Construction

骨架材料 Bobbin material	PBT/PA66/PPS/PET
铜线等级 Coil wire	Class F wire, -155°C ; Class H wire, - 200°C(IEC317-8)
支架 Magnetic yoke	Made by low carbon iron 高导磁低碳钢
封塑材料 Encapsulation material	PA66 30% fiberglass thermoplastic material 热塑性塑封料

接电方式 / Electrical Connections

插脚式 DIN43650 spade plug 2 line

应用 / Application

适用于液压电磁阀。

Suitable for hydraulic system solenoid valves.

液压类电磁阀线圈



Hydraulic Solenoid Coil



产品型号 / Coil type.:13373

产品编号 / Code no.:BRS-C018

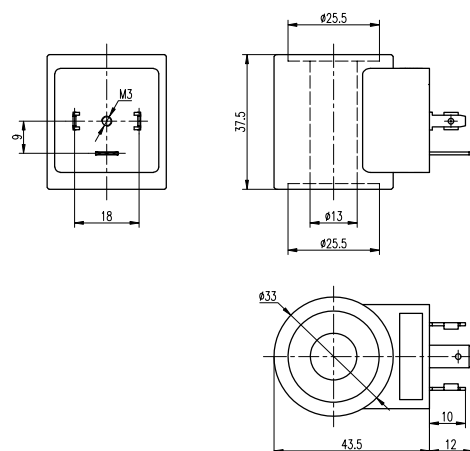

技术参数 / Technical Data

标称电压 Standard Voltage	DC:12V/24V; AC:24V/220V/380V (or RAC)
电压范围 Voltage range	DC \pm 10%; AC -15%~+10%
额定功率 Rated Power	AC:15VA/20VA; DC:18W, others on request 其它可定制
工作时间 Duty Cycle	ED100% (continuous)

保护等级 Protection degree	IP65(EN60529)
绝缘等级 Coil Insulation	Class H
环境温度 Ambient temperature	-20°C~+50°C
工作频率 Frequency	50/ 60 HZ

主要结构 / General Construction

骨架材料 Bobbin material	PBT/PA66/PPS/PET
铜线等级 Coil wire	Class F wire, -155°C ; Class H wire, - 200°C(IEC317-8)
支架 Magnetic yoke	Made by low carbon iron 高导磁低碳钢
封塑材料 Encapsulation material	PA66 30% fiberglass thermoplastic material 热塑性塑封料

接电方式 / Electrical Connections

插脚式 DIN43650A spade plug

应用 / Application

适用于液压电磁阀。

Suitable for hydraulic system solenoid valves.

液压类电磁阀线圈



Hydraulic Solenoid Coil



产品型号 / Coil type.:16522

产品编号 / Code no.:BRS-C019

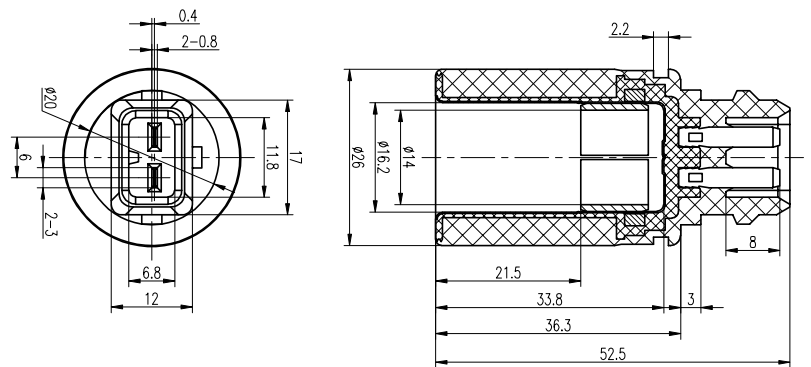

技术参数 / Technical Data

标称电压 Standard Voltage	DC:12V/24V,others on request
电压范围 Voltage range	DC±10%
额定功率 Rated Power	DC:23W, others on request 其它可定制
工作时间 Duty Cycle	ED100% (continuous)

保护等级 Protection degree	IP65(EN60529)
绝缘等级 Coil Insulation	Class H
环境温度 Ambient temperature	-20°C~+50°C
工作频率 Frequency	50/ 60 HZ

主要结构 / General Construction

骨架材料 Bobbin material	PBT/PA66/PPS/PET
铜线等级 Coil wire	Class F wire,-155°C ; Class H wire,- 200°C(IEC317-8)
支架 Magnetic yoke	Made by low carbon iron 高导磁低碳钢
封塑材料 Encapsulation material	PA66 30% fiberglass 热塑性塑封料 thermoplastic material

接电方式 / Electrical Connections

DEUTCH

应用 / Application

适用于液压电磁阀。

Suitable for hydraulic system solenoid valves.

液压类电磁阀线圈



Hydraulic Solenoid Coil



产品型号 / Coil type.:16602

产品编号 / Code no.:BRS-C020

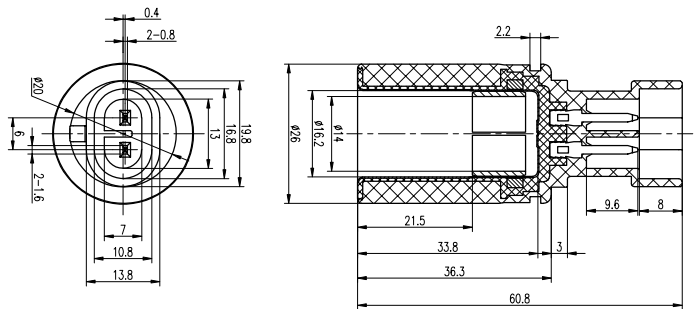

技术参数 / Technical Data

标称电压 Standard Voltage	DC:12V/24V,others on request
电压范围 Voltage range	DC±10%
额定功率 Rated Power	DC:23W, others on request 其它可定制
工作时间 Duty Cycle	ED100% (continuous)

保护等级 Protection degree	IP65(EN60529)
绝缘等级 Coil Insulation	Class H
环境温度 Ambient temperature	-20°C~+50°C
工作频率 Frequency	50/ 60 HZ

主要结构 / General Construction

骨架材料 Bobbin material	PBT/PA66/PPS/PET
铜线等级 Coil wire	Class F wire,-155°C ; Class H wire,- 200°C(IEC317-8)
支架 Magnetic yoke	Made by low carbon iron 高导磁低碳钢
封塑材料 Encapsulation material	PA66 35% fiberglass thermoplastic material 热塑性塑封料

接电方式 / Electrical Connections

插脚式 DIN43650A spade plug

应用 / Application

适用于液压电磁阀。

Suitable for hydraulic system solenoid valves.

汽配类电磁阀线圈



Automotive Solenoid Coil



产品型号 / Coil type.:ABS3550

产品编号 / Code no.:BRS-C021

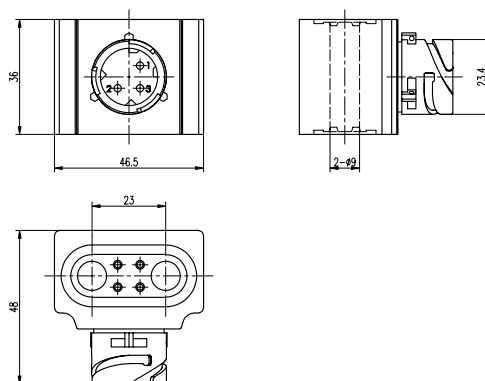

技术参数 / Technical Data

标称电压 Standard Voltage	12VDC/24VDC,others on request
电压范围 Voltage range	DC±10%
额定功率 Rated Power	DC:26W/37.5W,others on request 其它可定制
工作时间 Duty Cycle	ED100% (continuous)

保护等级 Protection degree	IP65(EN60529)
绝缘等级 Coil Insulation	Class H
环境温度 Ambient temperature	-20°C~+50°C
工作频率 Frequency	50/ 60 HZ

主要结构 / General Construction

骨架材料 Bobbin material	PBT/PA66/PPS/PET
铜线等级 Coil wire	Class F wire,-155°C ; Class H wire,- 200°C(IEC317-8)
支架 Magnetic yoke	Made by low carbon iron 高导磁低碳钢
封塑材料 Encapsulation material	BMC thermosetting material 热固性塑封料

接电方式 / Electrical Connections

DEUTCH

应用 / Application

适用于汽车 ABS 系统电磁阀。
Use for Automotive ABS System.

汽配类电磁阀线圈



Automotive Solenoid Coil



产品型号 / Coil type.:10333

产品编号 / Code no.:BRS-C022

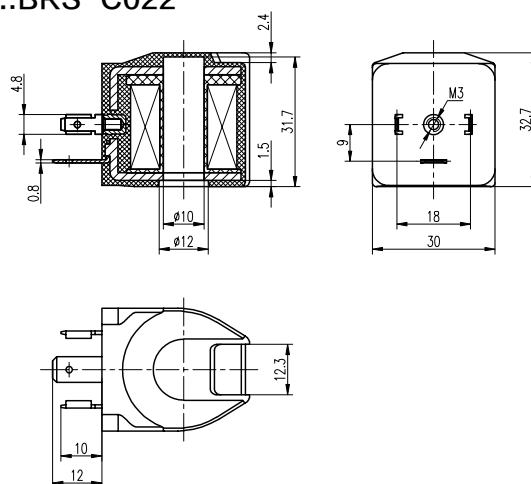

技术参数 / Technical Data

标称电压 Standard Voltage	12VDC/24VDC,others on request
电压范围 Voltage range	DC: -25%~+30%
额定功率 Rated Power	DC: 8W,others on request 其它可定制
工作时间 Duty Cycle	ED100% (continuous)

保护等级 Protection degree	IP65(EN60529)
绝缘等级 Coil Insulation	Class H
环境温度 Ambient temperature	-40°C~+50°C
工作频率 Frequency	50/ 60 HZ

主要结构 / General Construction

骨架材料 Bobbin material	PBT/PA66/PPS/PET
铜线等级 Coil wire	Class H wire,-180°C(IEC317-8)
支架 Magnetic yoke	Made by low carbon iron 高导磁低碳钢
封塑材料 Encapsulation material	BMC thermosetting material 热固性塑封料

接电方式 / Electrical Connections

插脚式 DIN43650A Spade plug

应用 / Application

适用于汽车尾气处理系统电磁阀。

Use for Automotive tail gas treatment.

汽配类电磁阀线圈



Automotive Solenoid Coil



产品型号 / Coil type.:12372

产品编号 / Code no.:BRS-C023

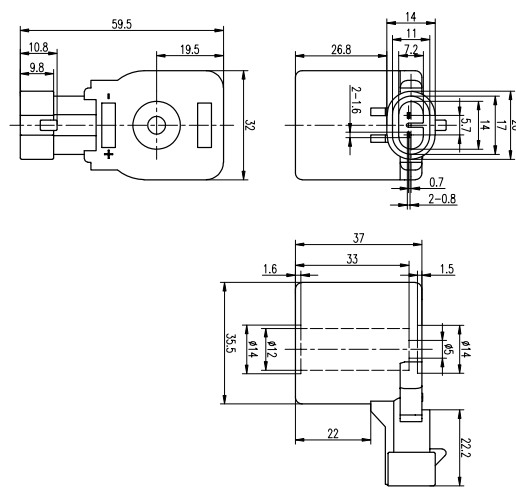

技术参数 / Technical Data

标称电压 Standard Voltage	12VDC/24VDC,others on request
电压范围 Voltage range	DC: -25%~+30%
额定功率 Rated Power	DC: 24W,others on request 其它可定制
工作时间 Duty Cycle	ED100% (continuous)

保护等级 Protection degree	IP65(EN60529)
绝缘等级 Coil Insulation	Class R
环境温度 Ambient temperature	-40°C~+120°C
工作频率 Frequency	50/ 60 HZ

主要结构 / General Construction

骨架材料 Bobbin material	PBT/PA66/PPS/PET
铜线等级 Coil wire	Class H wire,-200°C (IEC317-8)
支架 Magnetic yoke	Made by low carbon iron 高导磁低碳钢
封塑材料 Encapsulation material	PA66 30% fiberglass 热塑性塑料封料

接电方式 / Electrical Connections

DEUTCH

应用 / Application

适用于汽车 SCR 系统电磁阀。
Use for Automotive SCR System.

汽配类电磁阀线圈



Automotive Solenoid Coil



产品型号 / Coil type.:14322

产品编号 / Code no.:BRS-C024

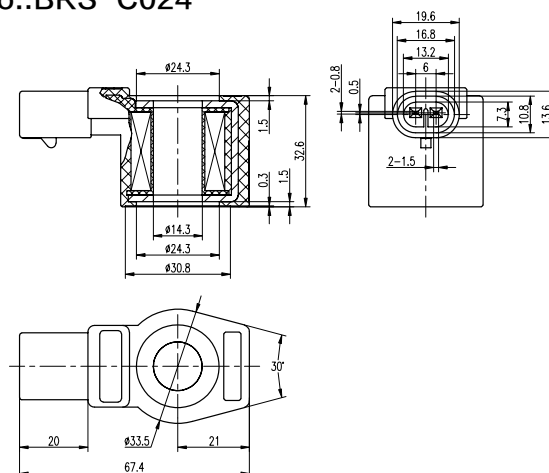

技术参数 / Technical Data

标称电压 Standard Voltage	12VDC/24VDC,others on request
电压范围 Voltage range	DC: -25%~+30%
额定功率 Rated Power	DC: 13W,others on request 其它可定制
工作时间 Duty Cycle	ED100% (continuous)

保护等级 Protection degree	IP65(EN60529)
绝缘等级 Coil Insulation	Class H
环境温度 Ambient temperature	-40°C~+120°C
工作频率 Frequency	50/ 60 HZ

主要结构 / General Construction

骨架材料 Bobbin material	PBT/PA66/PPS/PET
铜线等级 Coil wire	Class R wire, - 220°C (IEC317-8)
支架 Magnetic yoke	Made by low carbon iron 高导磁低碳钢
封塑材料 Encapsulation material	PA66 30% fiberglass thermoplastic material 热塑性塑封料

接电方式 / Electrical Connections

DEUTCH

应用 / Application

适用于汽车 SCR 系统电磁阀。

Use for Automotive SCR System.

汽配类电磁阀线圈



Automotive Solenoid Coil



产品型号 / Coil type.:14352

产品编号 / Code no.:BRS-C025

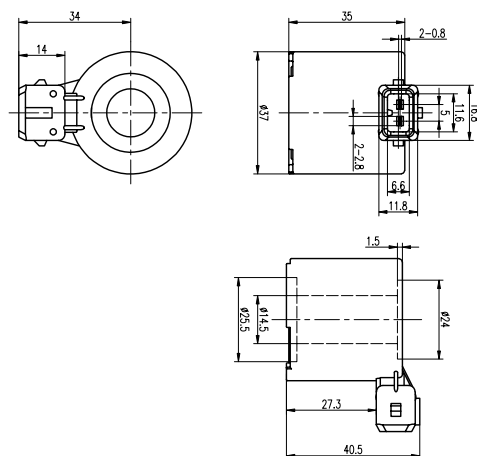

技术参数 / Technical Data

标称电压 Standard Voltage	12VDC/24VDC,others on request
电压范围 Voltage range	DC: -25%~+30%
额定功率 Rated Power	DC: 18W,others on request 其它可定制
工作时间 Duty Cycle	ED100% (continuous)

保护等级 Protection degree	IP65(EN60529)
绝缘等级 Coil Insulation	Class R
环境温度 Ambient temperature	-40°C~+120°C
工作频率 Frequency	50/ 60 HZ

主要结构 / General Construction

骨架材料 Bobbin material	PBT/PA66/PPS/PET
铜线等级 Coil wire	Class R wire,-220°C (IEC317-8)
支架 Magnetic yoke	Made by low carbon iron 高导磁低碳钢
封塑材料 Encapsulation material	PA6T fiberglass reinforced thermoplastic 热塑性塑封料 material

接电方式 / Electrical Connections

DEUTCH

应用 / Application

适用于 CNG 汽车发动机压力调节电磁阀。
Use for CNG pressure regulator of
Automotive engine chamber.

汽配类电磁阀线圈



Automotive Solenoid Coil



产品型号 / Coil type.:15302

产品编号 / Code no.:BRS-C026

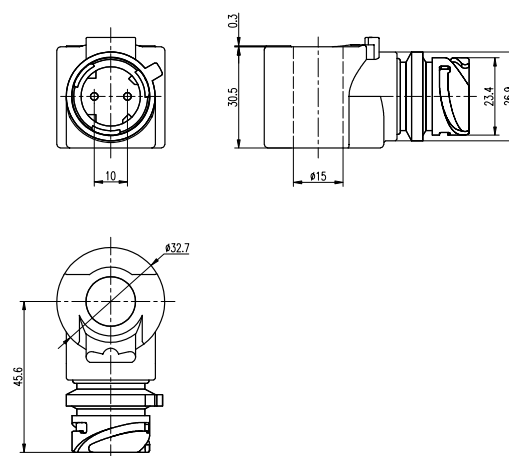

技术参数 / Technical Data

标称电压 Standard Voltage	12VDC/24VDC,others on request
电压范围 Voltage range	DC: $\pm 10\%$
额定功率 Rated Power	DC: 13W,others on request 其它可定制
工作时间 Duty Cycle	ED100% (continuous)

保护等级 Protection degree	IP65(EN60529)
绝缘等级 Coil Insulation	Class R
环境温度 Ambient temperature	-20°C~+50°C
工作频率 Frequency	50/ 60 HZ

主要结构 / General Construction

骨架材料 Bobbin material	PBT/PA66/PPS/PET
铜线等级 Coil wire	Class R wire, - 220°C (IEC317-8)
支架 Magnetic yoke	Made by low carbon iron 高导磁低碳钢
封塑材料 Encapsulation material	BMC thermosetting material 热固性塑封料

接电方式 / Electrical Connections

DEUTCH

应用 / Application

适用于汽车 SCR 系统, 汽车防冻液电磁阀。

Use for Automotive SCR system, Automotive valve for Antifreeze fluid.

电子类电磁阀线圈



Electric Solenoid Coil



产品型号 / Coil type.:1030

产品编号 / Code no.:BRS-C027

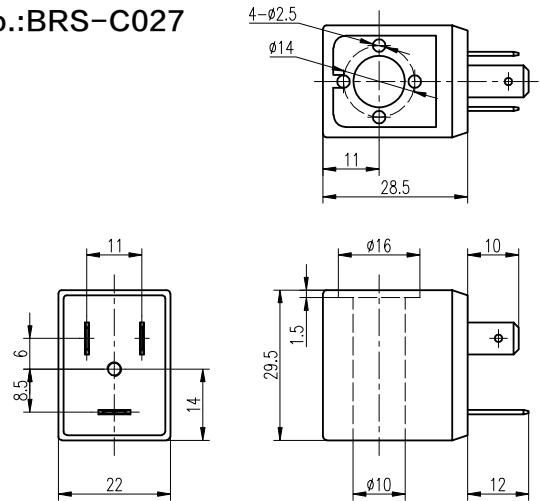

技术参数 / Technical Data

标称电压 Standard Voltage	DC:12V/24V; AC:24V/110V/220V
电压范围 Voltage range	DC \pm 10%,AC-10%~+15%
额定功率 Rated Power	AC: 5.5VA; DC:4.8W; others on request 其它可定制
工作时间 Duty Cycle	ED100% (continuous)

保护等级 Protection degree	IP65(EN60529)
绝缘等级 Coil Insulation	Class F, H
环境温度 Ambient temperature	-20°C~+50°C
工作频率 Frequency	50/ 60 HZ

主要结构 / General Construction

骨架材料 Bobbin material	PBT/PA66/PPS/PET
铜线等级 Coil wire	Class F wire,-155°C ; Class H wire,- 200°C(IEC317-8)
支架 Magnetic yoke	Made by low carbon iron 高导磁低碳钢
封塑材料 Encapsulation material	PA66 30% fiberglass 热塑性塑料 thermoplastic material

接电方式 / Electrical Connections

插脚式 DIN43650B Spade plug

应用 / Application

广泛应用于家电，气动，蒸汽等行业。

Suit for solenoid valve which widely used in small Household Appliances,Pneumatics,Steam industries.

电子类电磁阀线圈



Electric Solenoid Coil



产品型号 / Coil type.:10303

产品编号 / Code no.:BRS-C028

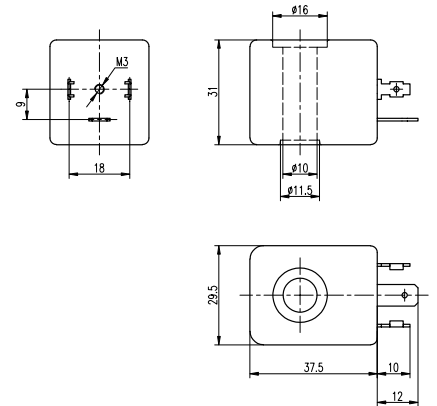

技术参数 / Technical Data

标称电压 Standard Voltage	DC:12V/24V; AC:24V/110V/220V
电压范围 Voltage range	DC \pm 10%,AC-10%~15%
额定功率 Rated Power	AC: 5.5VA; DC:4.8W; others on request 其它可定制
工作时间 Duty Cycle	ED100% (continuous)

保护等级 Protection degree	IP65(EN60529)
绝缘等级 Coil Insulation	Class F, H
环境温度 Ambient temperature	-20 $^{\circ}$ C~+50 $^{\circ}$ C
工作频率 Frequency	50/ 60 HZ

主要结构 / General Construction

骨架材料 Bobbin material	PBT/PA66/PPS/PET
铜线等级 Coil wire	Class F wire, -155 $^{\circ}$ C ; Class H wire, - 200 $^{\circ}$ C(IEC317-8)
支架 Magnetic yoke	Made by low carbon iron 高导磁低碳钢
封塑材料 Encapsulation material	PA66 30% fiberglass thermoplastic material 热塑性塑封料

接电方式 / Electrical Connections

插脚式 DIN43650B Spade plug

应用 / Application

广泛应用于家电, 气动, 蒸汽等行业。

Suit for solenoid valve which widely used in small Household Appliances,Pneumatics,Steam industries.

制冷类电磁阀线圈



Pneumatic Solenoid Coil



产品型号 / Coil type.:10242

产品编号 / Code no.:BRS-C029

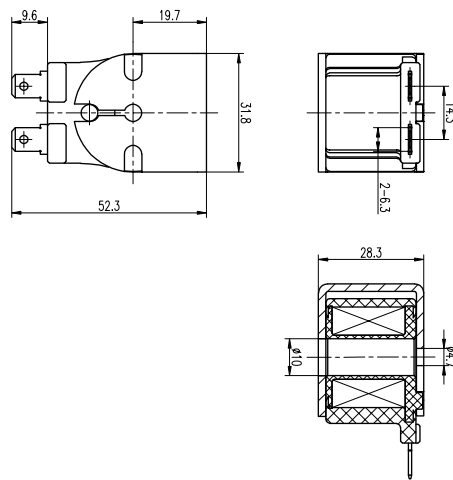

技术参数 / Technical Data

标称电压 Standard Voltage	AC:24V/220V,others on request
电压范围 Voltage range	DC±10%
额定功率 Rated Power	AC:8W, others on request 其它可定制
工作时间 Duty Cycle	ED100% (continuous)

保护等级 Protection degree	IP67(water-proof)
绝缘等级 Coil Insulation	Class H
环境温度 Ambient temperature	-20°C~+50°C
工作频率 Frequency	50/ 60 HZ

主要结构 / General Construction

骨架材料 Bobbin material	PBT/PA66/PPS/PET
铜线等级 Coil wire	Class H wire,-180°C (IEC317-8)
支架 Magnetic yoke	Made by low carbon iron 高导磁低碳钢
封塑材料 Encapsulation material	Fiberglass reinforced PET 热塑性塑封料

接电方式 / Electrical Connections

Spade terminals 6.3*0.8mm(DIN46340)

应用 / Application

广泛用于制冷、空调、热泵系统中制冷剂的的控制用电磁阀。
Widely used for the control of the refrigerant in refrigeration, air conditioning and heat pumps systems.

制冷类电磁阀线圈



Pneumatic Solenoid Coil



产品型号 / Coil type.:R1135

产品编号 / Code no.:BRS-C030

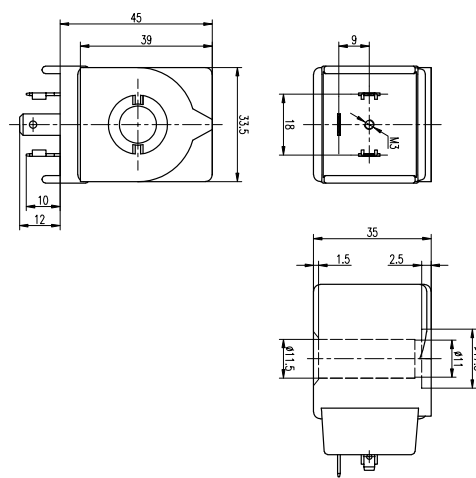

技术参数 / Technical Data

标称电压 Standard Voltage	AC:24V/220V/380V,others on request
电压范围 Voltage range	AC:-15%~+10%
额定功率 Rated Power	AC:15VA, others on request 其它可定制
工作时间 Duty Cycle	ED100% (continuous)

保护等级 Protection degree	IP65(EN60529)
绝缘等级 Coil Insulation	Class H
环境温度 Ambient temperature	-20°C~+50°C
工作频率 Frequency	50/ 60 HZ

主要结构 / General Construction

骨架材料 Bobbin material	PBT/PA66/PPS/PET
铜线等级 Coil wire	Class F wire,-155°C; Class H wire,- 200°C(IEC317-8)
支架 Magnetic yoke	Made by low carbon iron 高导磁低碳钢
封塑材料 Encapsulation material	PA66 30% fiberglass thermoplastic materia 热塑性塑封料

接电方式 / Electrical Connections

插脚式 DIN43650A spade plug

应用 / Application

广泛用于制冷、空调、热泵系统中制冷剂的控制用电磁阀。
Widely used for the control of the refrigerant in refrigeration, air conditioning and heat pumps systems.

纺织类电磁阀线圈



Textile Solenoid Coil



产品型号 / Coil type.: 10mm

产品编号 / Code no.: BRS-C031

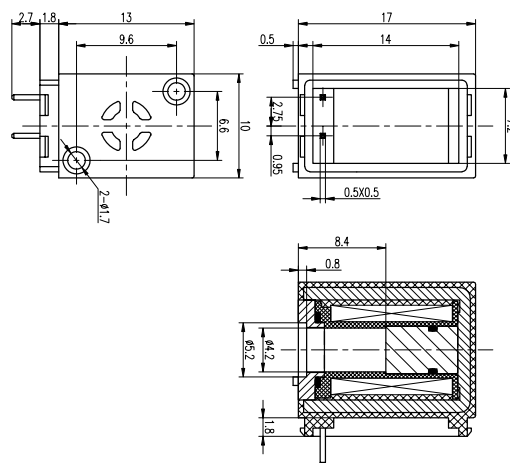

技术参数 / Technical Data

标称电压 Standard Voltage	DC: 12V/24V; AC: 110V/220V
电压范围 Voltage range	DC: $\pm 10\%$; AC: $-10\% \sim +15\%$
额定功率 Rated Power	AC: 2 VA; DC 1.2W; others on request 其它可定制
工作时间 Duty Cycle	ED100% (continuous)

保护等级 Protection degree	IP65 (EN60529)
绝缘等级 Coil Insulation	Class H
环境温度 Ambient temperature	$-20^{\circ}\text{C} \sim +50^{\circ}\text{C}$
工作频率 Frequency	50/ 60 HZ

主要结构 / General Construction

骨架材料 Bobbin material	PBT/PA66/PPS/PET
铜线等级 Coil wire	Class H wire- 180°C (according to IEC317-8)
支架 Magnetic yoke	Made by low carbon iron 高导磁低碳钢
封塑材料 Encapsulation material	PA66 30% fiberglass 热塑性塑封料

接电方式 / Electrical Connections

端子或引线式 Terminal or flying leads

应用 / Application

广泛应用于纺织、医疗、电子、轻工、机械等领域。
Widely used in textile, medical, electronics, light industry, machinery and other fields.

纺织类电磁阀线圈



Textile Solenoid Coil



产品型号 / Coil type.:15mm

产品编号 / Code no.:BRS-C032

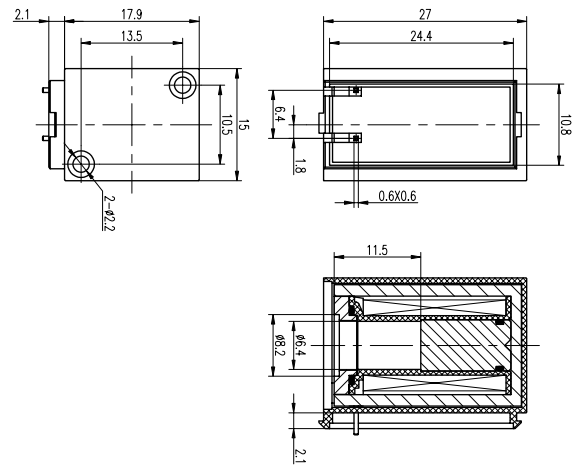

技术参数 / Technical Data

标称电压 Standard Voltage	DC:12V/24V
电压范围 Voltage range	DC±10%
额定功率 Rated Power	DC1.6W; others on request 其它可定制
工作时间 Duty Cycle	ED100% (continuous)

保护等级 Protection degree	IP65(EN60529)
绝缘等级 Coil Insulation	Class H
环境温度 Ambient temperature	-20°C~+50°C
工作频率 Frequency	50/ 60 HZ

主要结构 / General Construction

骨架材料 Bobbin material	PBT/PA66/PPS/PET
铜线等级 Coil wire	Class H wire -180°C (according to IEC317-8)
支架 Magnetic yoke	Made by low carbon iron 高导磁低碳钢
封塑材料 Encapsulation material	PA66 30% fiberglass thermoplastic materia 热塑性塑料封料

接电方式 / Electrical Connections

端子或引线式 Terminal or flying leads

应用 / Application

广泛应用于纺织、医疗、电子、轻工、机械等领域。
Widely used in textile, medical, electronics, light industry, machinery and other fields.